

MOTTO

DOUBLE BUCKET TROLLEY

CLEAN DESIGN
FOR CLEANING DUTIES



MOTTO - IPC'S COMPACT DOUBLE BUCKET TROLLEY



IPC

BY TENNANT COMPANY

MOTTO

OVERVIEW

WHY **MOTTO**

COMPACT DESIGN

DESIGNED FOR THE USER

TECHNICAL SPECIFICATIONS

CONFIGURATIONS AND ACCESSORIES



Overview

The compact double bucket trolley designed to meet any space requirements.

MOTTO is born from IPC's experience with the goal of improving usability for operators, thanks to its compactness and maneuverability.

Its reduced dimensions and the ease of assembly/disassembly make it convenient to use and transport, even for smaller professional cleaning environments.

MOTTO's design focuses on operator comfort, with 25-litre buckets featuring an increased width for easier mop insertion during rinsing, and a higher handlebar for enhanced ergonomic pushing.

Compared to IPC's previous compact trolley model '2P,' **MOTTO** features a more compact and concealed structure, reducing its width and depth, allowing it to be used in tight spaces, occupying less storage space.

MOTTO is designed with sustainability in mind. It uses recycled plastic for the base and buckets. Additionally, its design reduces logistical impact thanks to a smaller box size compared to the previous '2P' model, improving transport and storage efficiency.

The design emphasizes essential elements such as the buckets and push handle. The structure has been simplified without compromising strength and durability, thanks to a solid base and wheels bolted for greater robustness compared to snap-on wheels, which are prone to detachment.



Why MOTTO



FAST AND SIMPLE ASSEMBLY

The package includes the base with pre-attached wheels secured by bolts. Simply mount the wringer support on the base and attach the handlebar using the convenient green clips provided. The entire process takes just a few minutes. An assembly manual is included.

EASY TO TRANSPORT

The trolley's bulk can be reduced thanks to stackable buckets and a detachable handlebar, making it ideal for transportation in limited spaces.

COMPACT

The compact design also results in optimized packaging. Each box contains all the necessary components for one trolley, and thanks to its reduced size compared to the previous model, more units can be transported per pallet, optimizing storage space.



ERGONOMICS

Our designers have studied the optimal height for the push handle. The height is designed to best suit individuals between 150 and 180 centimeters tall.

FUNCTIONAL

The 25-litre buckets have a 22% wider opening compared to the previous '2P' model, making mop insertion easier.

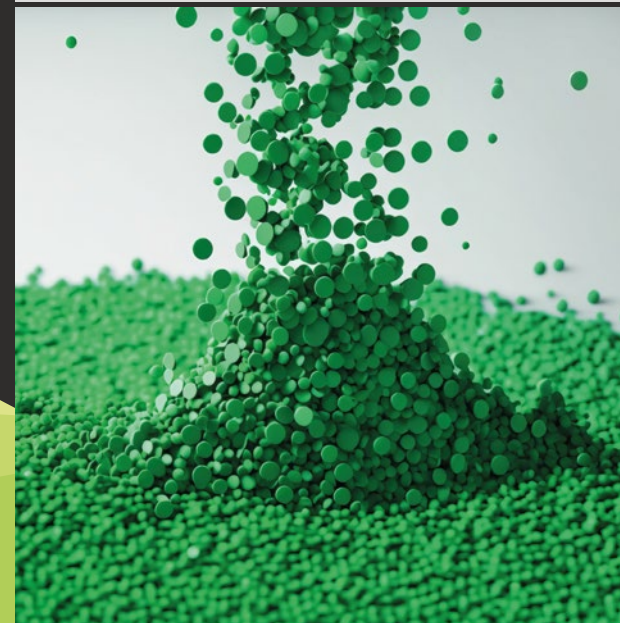

RECYCLED PLASTIC

The base and buckets are made from recycled plastic. The single 15- and 25-litre buckets have a declared plastic percentage of 78%. The various trolley configurations, on the other hand, have a declared recycled plastic percentage of 37%.

The percentages are calculated based on the recycled material's impact on the total trolley weight.

Compact design

Maneuverability and compactness

They make the **MOTTO** trolley an ideal ally for small spaces up to 100 square metres. The trolley is 7% smaller than the previous 2P model and, thanks to its shape and ergonomics, makes it easy to use, making it suitable for cleaning work on surfaces of all.

IPC **MOTTO** (Platinum and Gold)

L (mm)	W (mm)	H (mm)
695	400	971

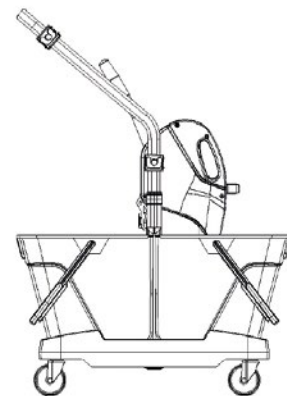
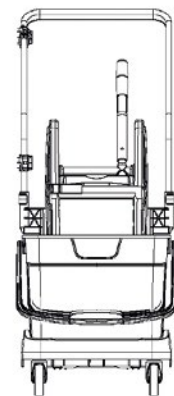
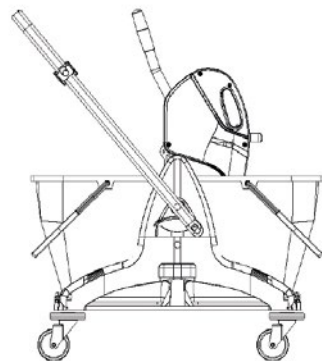
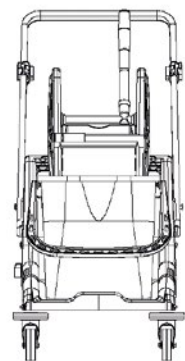

Smart packaging

One crucial aspect of the design is packaging optimization for logistics. The **MOTTO** trolley packaging is smaller than the 2P model, with dimensions of 590 x 400 x 530 mm.

This results in a 45% reduction in packaging volume, with all the necessary components for one trolley included. Compared to the previous model, the **MOTTO** trolley allows for a 60% increase in units per pallet.

	2P CARR00239	MOTTO CARR03533 (new)
Pallet size	1200 mm x 800 mm	1200 mm x 800 mm
Pieces/Ptt	10	16
Pallet height	2315 mm	2310 mm

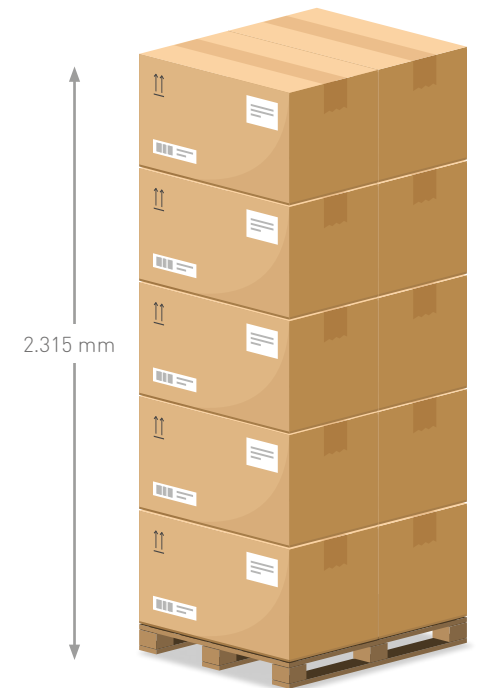

2P's Palletization
783mm x 433mm x 516mm = 0,184mc



MOTTO's Palletization
590mm x 400mm x 530mm = 0,127mc

Designed for the user

MOTTO's design is developed on two distinct fronts: aesthetics and functionality.

The first aspect concerns the design and product recognizability. The structural part is concealed, leaving space for the widened shape of the 25-liter buckets. The compact size maintains maneuverability and allows for reduced packaging, leading to better logistics management compared to the previous model.

The second aspect is product functionality. **MOTTO** is designed to be easily assembled and to improve the ergonomics of the push handle compared to IPC's previous model.

Particular attention has been given to the height of the push handle. The handle's height is crucial for making the product comfortable for most users.

The dimensional consideration to find the correct handle height was made by taking into account the comfort during pushing and the natural and correct inclination of the forearm during trolley movement.

The handle is designed to be comfortable for both male and female users in the 50th percentile of height.

The optimal opening angle of the handle, which allows for the most natural arm position without muscle strain, typically ranges between 110° and 120°.

The handle's inclination naturally aligns with the forearm position for most users, and the opening angle helps keep the handle within the trolley's footprint, reducing the risk of tipping when pushed forcefully downward. The higher grip point compared to the previous 2P model allows users to maintain an upright posture.

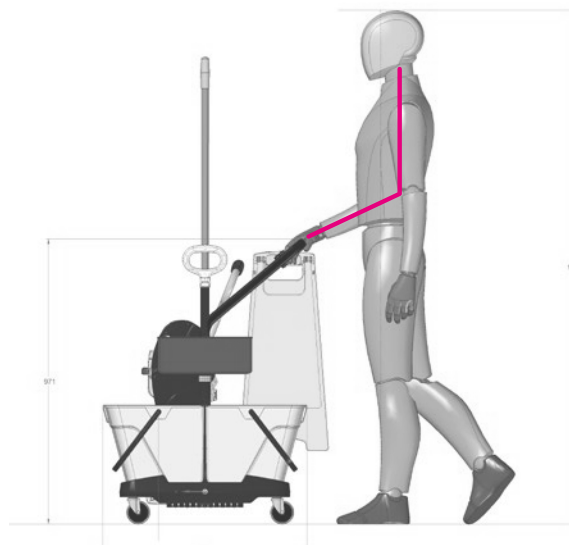

50th percentile male | inclination of the forearm during pushing.

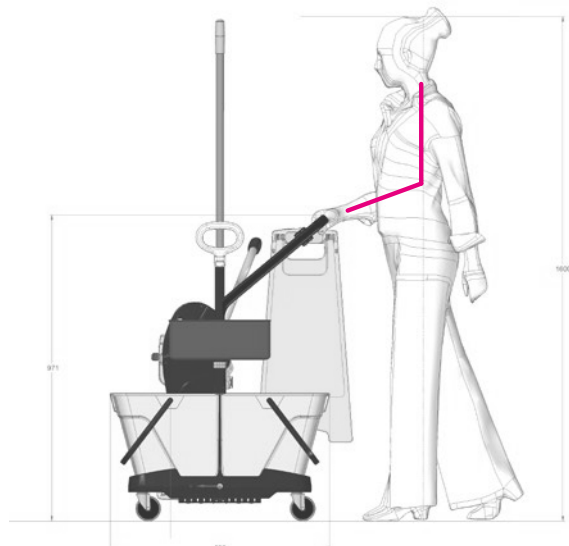

50th percentile female | inclination of the forearm during pushing.



Technical specifications

ERGONOMIC HANDLE

The black-painted handle, increased in height for ergonomic pushing.

CLIPS

For easy attachment and removal of the handle.

WIDENED 25-LITRE BUCKETS

With a widened mouth that increases the mop insertion area by 22% compared to the previous model.

COLORED INSERTS

For easy identification using color codes.

WHEELS

Metal wheels, 80mm in diameter, bolted to the base.

10

11



Configurations

Accessories



KTRI06757

KTRI06757 The kit includes a handle holder, broom base, tray, and safety sign holder.

- MPVR94619 0099
Black polypropylene tray
- MPVR94778 0081
Silk grey handle holder
- MPVR94765 0081
Silk grey safety sign holder
- MPVR94835 0099
Black broom base



12

13

Platinum

CARR53533

- 25L buckets in silk grey color
- Handlebar
- Kinetic wringer with ergonomic wringing handle, compatible with flat mops with flaps and traditional mops
- 80mm diameter metal wheels
- Black base
- 2x black accessory fixing clips

Gold

CARR03533

- 25L buckets in silk color
- Handlebar
- New Line wringer, compatible with flat mops with flaps and traditional mops
- Metal wheels
- Black base
- 2x black accessory fixing clips

Silver

CARR03532

- 15L buckets in silk color
- Side handle
- New Line wringer, compatible with flat mops with flaps and traditional mops
- Metal wheels
- Black base



IPC

BY TENNANT COMPANY

IPC Tools SpA

Made in Italy 

www.ipcworldwide.com

© 2024 Tennant Company. All Rights Reserved